

Oil Debris Sensor Inflow Adaptor

Technical Specification

The Gill Inflow adaptor allows installation of the Oil Debris Sensor head at a convenient position within the lubrication bypass circuit of the equipment.

Fitted to pipe sizes of up to 1.5" diameter, the adaptor uses a bespoke mounting flange that fits the Gill Oil Debris Sensor head, ensuring convenient positioning and full functionality of both the ferrous debris and dielectric sensors are available.

Using standard industrial pipe fittings ensures a wide range of additional pipe size reducers, hose fittings and isolation valves can be specified according to requirements.



** Sensor available separately*

Typical Applications

- Engines
- Gearboxes
- Pumps
- Hydraulics

Key Features

- Bespoke sensor head mount (*Image a*)
- Industry Standard BSP connections
- Stainless steel construction for durability
- Designed for M20 X 1.5 sensor head fitting



Image a

Advantages

- Flexibility over positioning in the lubricating circuit makes it easy to position the sensor for best performance.
- Can be used with a range of pipe diameter sizes when used with reducers. (not supplied)
- Compact, for installation where space is limited
- High quality stainless steel construction gives dependable long-life and corrosion-free service

Oil Debris Sensor Inflow Adaptor

Technical Specification

| Compatibility | |
|-----------------------------------|-------------|
| | 4212-00-161 |
| Oil Debris Sensor with Display | ✓ |
| Oil Debris Sensor without Display | ✓ |
| BSP 1.5" Connections | ✓ |
| BSP 1.25" Connections | ✓ |
| BSP 1" Connections | ✓ |
| BSP 0.75" Connections | ✓ |
| BSP 0.5" Connections | ✓ |
| BSP 0.375" Connections | ✓ |
| BSP 0.25" Connections | ✓ |

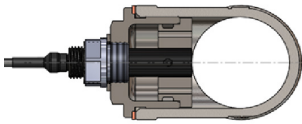
| Installation | |
|--|---|
|  |  |
| <p>Important. Ensure the sensor is mounted horizontally in the flow and upstream of any filters.</p> | |

| Materials | |
|---------------|--|
| Equal Tee | Stainless Steel 316 |
| Sensor Flange | Stainless Steel 316 with PTFE Sealing Washer |
| Hex Nipple | Stainless Steel 316 |

| Specification | |
|-----------------------|--|
| Hose Compatibility | 0.25" (6mm) - 1.5" (38mm) |
| Operating Temperature | -20°C to +200°C |
| Pressure Rating | <10 Bar |
| Oil Resistance | Hydraulic, Gear, Mineral, Vegetable, Semi-synthetic, Semi-ester, Polyalphaolefin, Polyalkyleneglycol |

| Ordering | |
|---|-------------|
| | 4212-00-161 |
| Sensor Mounting Tee | 1.5" |
| <p>Please note. Hose tails and size reducers will be required for smaller diameter pipe systems</p> | |

Specification may be subject to change without prior notice.

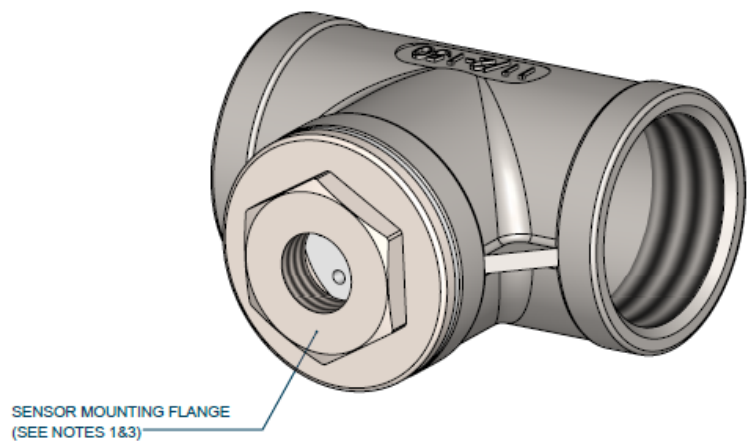
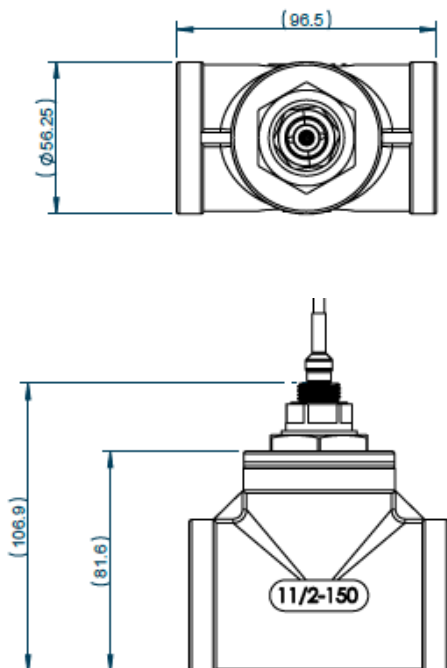

3D VIEW
SCALE 1:1