

WearDetect

Inflow Adaptor Kit

Quickstart Guide

4212-00-160-xxx

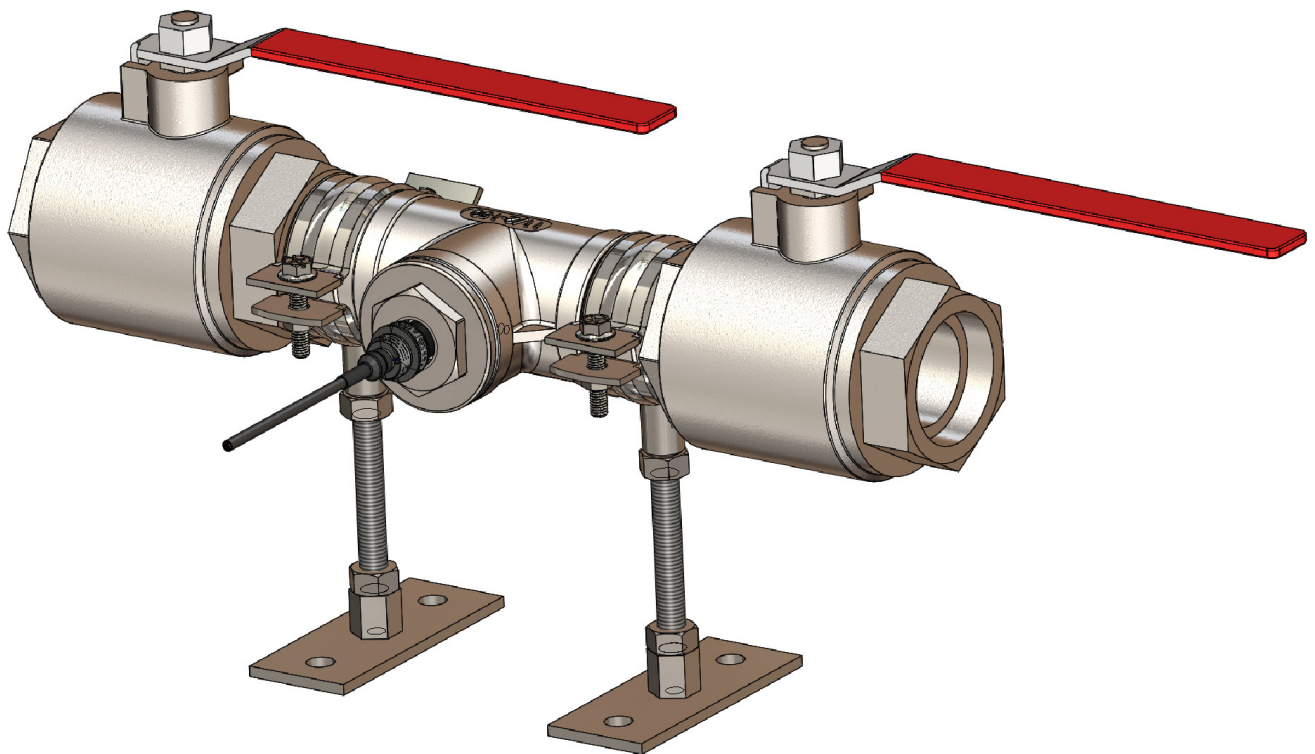

Installation

This sensor kit is designed to be installed within a lubrication bypass circuit, upstream of any filtration and uses standard 1.5" diameter pipe fittings. This kit allows optimum sensor operation in this configuration.

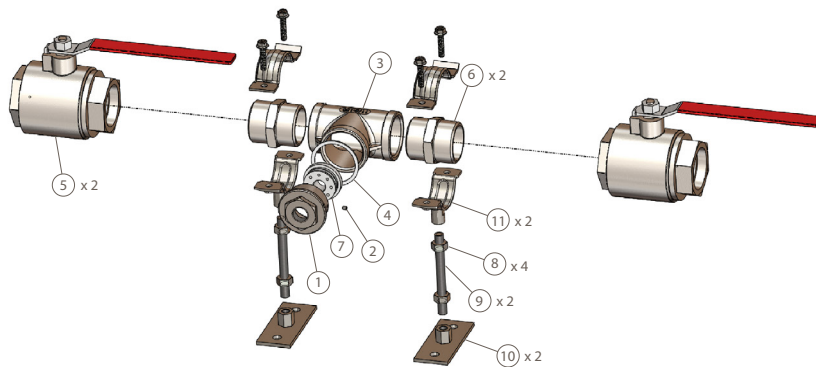

1. Sensor mounting flange
2. M4 x 5 socket set screw
3. Equal tee
4. PTFE sealing washer
5. Ball valve
6. Hex nipple
7. Sensor sleeve
8. M10 nut
9. M10 x 100 threaded stud
10. Mounting plate
11. Pipe clamp (complete clamp arrangement)

** Not supplied*

Installation guidelines:

1. Ensure the Oil Flow of machinery and both ball valves are shut off
2. Obtain hometail* and pipe clamp* to match your pipe diameter.
3. Secure the hex nipples (Item 6) into either side of the equal tee (Item 3).
4. Secure the ball valves (Item 5) into position on the free end of the hex nipples (Item 6). Ensure they are positioned such that they are able to be operated once installed. Gill recommend the use of PTFE tape or pipe sealant as necessary.
5. Secure additional pipe fittings* into the free end of the ball valves (Item 6).

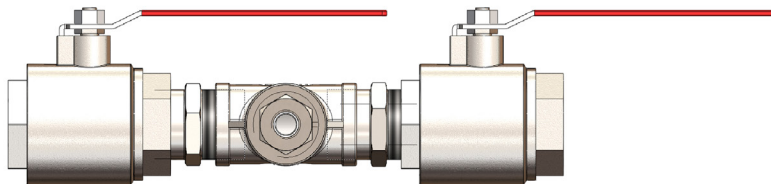

6. Measure according to the above diagram, drain system and cut and remove the measured section of hose / pipe, allowing for the correct pipe adaptors and thread engagement.

- Secure the adapter kit into position. Ensure the ball valves are positioned so the handles do not foul any other equipment or walls when in the closed position (valves can be installed either way round).
- Assemble and position the pipe clamps, mounting plates, studs and locking nuts and secure into position. Torque the clamp screws to $2\text{Nm} \pm 0.2\text{Nm}$. Use the M10 nuts (item 8) to lock the positions of the mounting plate (item 10) and pipe clamp (item 11).

Important!

Ensure the sensor is mounted horizontally in the flow

Ensure inflow kit is bonded to earth

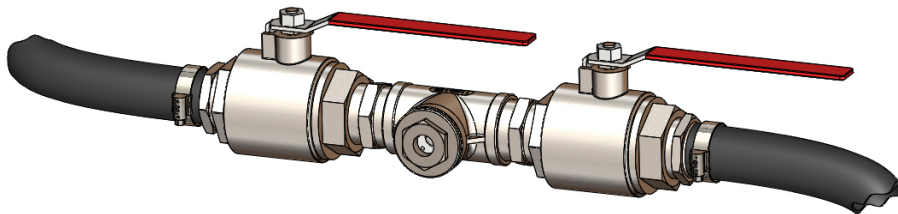

Pipe connections and hose tails shown for illustration purposes

- Ensure that the inflow kit installation is bonded to earth. This can be achieved with a ring terminal, or a pipe bonding earth clamp (not provided).

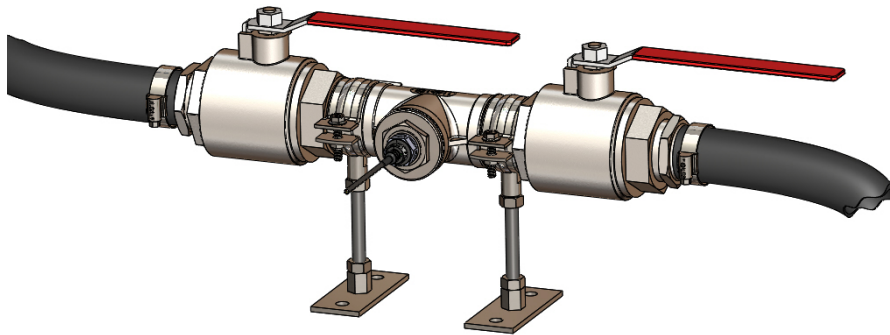
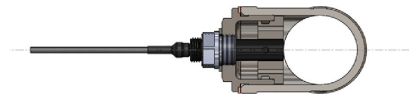

Pipe connections and hose tails shown for illustration purposes

- Configure your sensor prior to final installation (see product manual for configuration instructions).
- Fit the sensor into the adaptor and tighten to $8\text{Nm} \pm 0.8\text{Nm}$ torque setting.
- Ensure the valves are fully open and the locking tabs (if fitted) are fully engaged, bleed the system free from air.
- Check the system for leaks and tighten any leaking joints.

Service and Maintenance

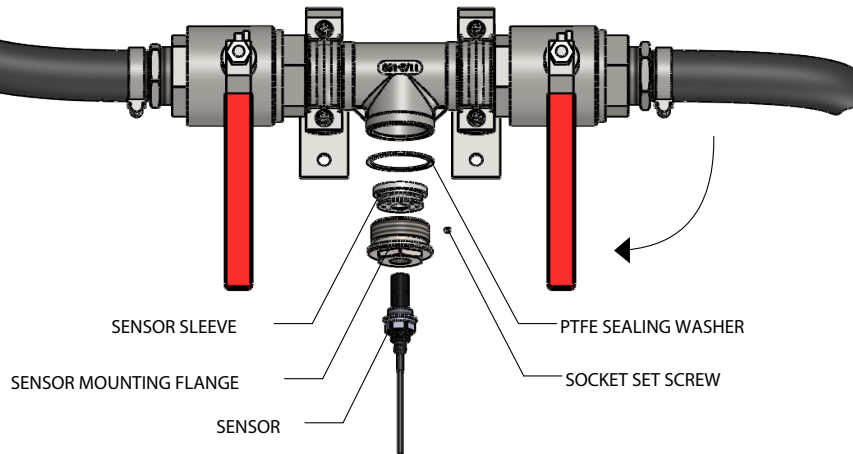

1. Ensure the valves are fully closed and the locking tabs (if fitted) are fully engaged before any cleaning or maintenance.
2. Locate a suitable catch tank (with >300ml capacity) below the installation to collect oil that drains from the inflow adaptor accessory.
3. Remove the sensor head using a 22mm spanner and carefully clean away any dirt or debris.
4. Remove the sensor mounting flange using a 36mm spanner.
5. Unscrew the socket set screw from the sensor mounting flange and slide the sensor sleeve out from the sensor mounting flange.
6. Carefully clean away any trapped dirt or debris from within the sensor sleeve and sensor mounting flange.
7. Slide the sensor sleeve back into the sensor mounting flange, ensure the sensor sleeve is fully inserted.
8. Secure the sensor sleeve into position using the socket set screw. Tighten to 0.3Nm +/-0.03Nm torque setting.
9. Ensure the PTFE sealing washer is fitted and screw the sensor mounting flange back into the equal tee. Tighten to 50Nm +/-5Nm torque setting.
10. Carefully wipe away any dirt or debris from the sensor and screw the sensor back into the sensor mounting flange. Tighten to 8Nm +/-0.8Nm torque setting.
11. Refill the system with any oil lost during the maintenance procedure.
12. Check for leaks and tighten as necessary.

Important!

Ensure the sensor sleeve is fully retained using the supplied socket set screw.