

WearDetect

Oil Debris Sensor

Quickstart Guide - Inflow Adaptor



Installation

This sensor adaptor is designed to be installed within a lubrication bypass circuit, upstream of any filtration and uses as standard 1.5" diameter industrial pipe fittings. The adapter allows optimum sensor operation in this configuration.

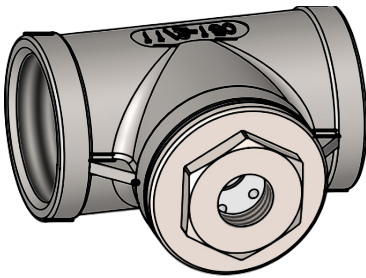

1. Measure the width of the adapter plus any additional fittings* needed to secure into the pipe circuit (e.g. hex nipple, hose tail).

** Not supplied*

Secure the adapter into the circuit pipework using PTFE tape or pipe sealant as necessary.

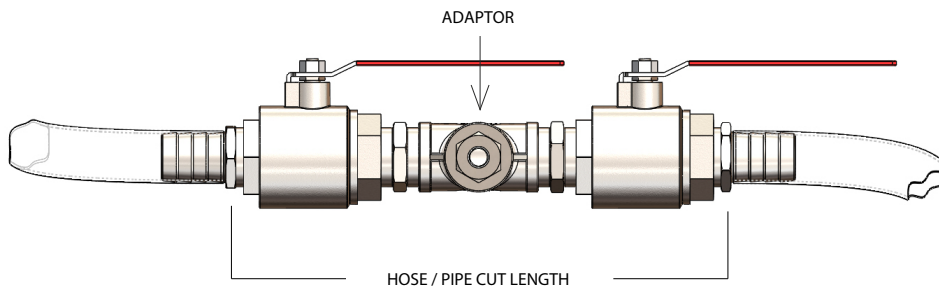

Important!

Ensure the sensor is mounted horizontally in the flow

Isolation valves and hose tails for illustration only

2. Configure the sensor prior to final installation (see product manual for configuration instructions).

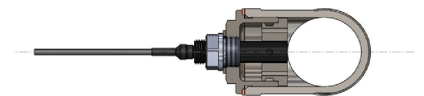
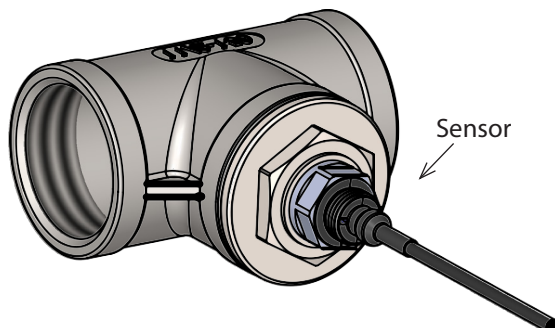

3. Once the adaptor is installed in the bypass circuit, secure the sensor head into the sensor mounting flange. Torque the sensor to 8nm +/-0.8nm using a 22mm spanner.

Service and Maintenance

1. Ensure the system is drained of oil and the adaptor is isolated before any cleaning or maintenance as necessary.

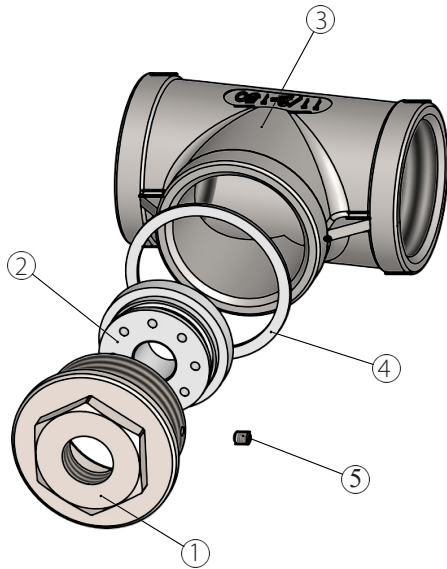

1. Sensor mounting flange
2. Sensor sleeve
3. 1.5" BSP equal tee
4. PTFE sealing washer
5. M4 x 5 socket set screw

2. Remove the sensor head using a 22mm spanner and carefully clean away any dirt or debris.
3. Remove the sensor mounting flange using 36mm spanner (item 1).
4. Unscrew the M4 x 5 socket set screw (item 5) from the sensor mounting flange and slide the sensor sleeve (item 2) out from the sensor mounting flange (item 1).
5. Carefully clean away any trapped dirt or debris from within the sensor sleeve (item 2) and sensor mounting flange (item 1).
6. Slide the sensor sleeve (item 2) back into the sensor mounting flange (item 1), ensuring the sensor sleeve (item 2) is fully inserted.
7. Secure the sensor sleeve (item 2) into position using the M4 x 5 socket set screw (item 5). Torque the screw to 0.3nm +/-0.03nm.
8. Ensure the PTFE sealing washer (item 4) is fitted, then screw the sensor mounting flange (item 1) back into the 1.5" equal tee (item 3). Torque the fitting to 50nm +/-5nm.
9. Carefully wipe away any dirt or debris from the sensor and screw the sensor back into the sensor mounting flange (item 1). Torque tighten the fitting to 8nm +/-0.8nm.
10. Refill the system with any oil lost during the maintenance procedure.

Important!

Use a suitable catch tank to collect the oil that drains from the Inflow adaptor fitting.

Important!

Ensure the sensor sleeve is fully retained using the supplied socket set screw.