

## Custom designed military grade liquid level sensors

Robust, reliable liquid level sensor for defence applications

Whether it's armoured vehicles, military transport vehicles or military marine craft, LevelDefend liquid level sensors deliver proven performance to the exacting standards required in critical applications and when security is paramount. Used as part of a larger system or vehicle, LevelDefend sensors provide robust, reliable and accurate liquid level measurement, to a diverse range of defence applications.

Supplied to customer requirements, LevelDefend capacitive level sensors are backed up by expert support from Gill, who design and manufacture in the UK, to give total peace of mind.



Military grade design

### Typical Applications

- Armoured vehicles
- Tactical vehicles
- All terrain vehicles
- Transport vehicles
- Military marine craft

### Key Features

- 6082 T6 anodised aluminium construction
- Solid state electronics
- Environmentally sealed design
- Can be used with bespoke liquids
- Compatible with fuels, oils, chemicals and water-based liquids

### Benefits

- Gill technology, proven in defence applications
- Factory calibrated to customer requirements
- Capacitive technology ensures uninterrupted measurement
- Endures shock, vibration and wide temperature ranges
- No moving parts to maintain
- Low EMC emissions



Proven in military applications

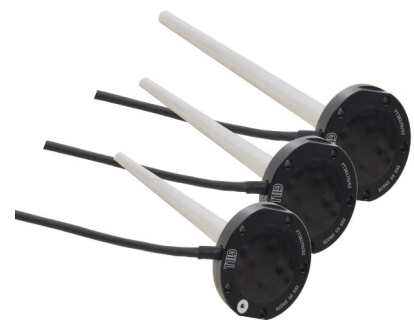

Robust design for long service

## Custom designed military grade liquid level sensors







Robust, reliable liquid level sensor for defence applications

GENERAL SPECIFICATION	
Accuracy	+/- 2% FSD @ 20°C
Linearity	+/- 2% FSD @ 20°C
Operating temperature	- 40°C to +125°C
Compatible media **	Aviation kerosene AVTUR F-34, Aviation kerosene AVTUR F-44 Military diesel NATO F-54 Civilian diesel GP UK MT Dieso Civilian diesel GP UK Dieso ** <i>Specified at order</i>
Seal materials	Axial - 3mm Viton O-rings

DIMENSIONS	
Overall length	Probe length + 18mm
Mounting flange height	18mm + 1.5mm nitrile gasket (5 Bolt)
Mounting flange Ø	63mm
Fixing bolt aperture Ø	5.1mm

ENVIRONMENTAL	
Ingress protection	IP67
Thermal shock	<i>Please contact Gill for more details on specific application suitability</i>
Vibration	
Humidity	
Pressure	
EMC	
<b>Has been used in military systems that adhere to DEF STAN 61-5 / MIL STD 1275, DEF STAN 59-411 / MIL STD-461F and DEF STAN 00-35 / MIL STD 810G</b>	

This product is not designed or certified for use in ATEX environments









TYPICAL CONNECTIONS		
		Designation
	Red	+V (Nominal 28V)
	Black	-V (Ground) 0V DC
	Yellow	4-20mA Loop
	White	Tx
	Green	Rx
	N/A	Spare

ELECTRICAL	
Output	4-20mA
Supply voltage	18-32V DC
Over voltage protection	> 40 V DC
Supply current @ 12 V DC	> 30 mA
Reverse polarity protection	to -32V DC
Resolution	10 Bit
Report rate	80 Hz
Sensor configuration *	RS232

OUTPUTS	
Current	4 – 20mA (3 wire + V. Signal and GND)

MECHANICAL	
Construction	Anodised aluminium 6082 T6, FEP, M3 earth stud
Probe length	<i>Please ask (see below)</i>
Mounting	SAE 5-Bolt
Weight	From 300g (dependent on length)
Cable	26 AWG , Type 44, DR25, side exit
Cable tail length	500mm

**\*USB – RS232 ADAPTOR (Part number 1484-00-086)**

USB – RS232		Sensor	
	Red		Red
	Black		Black
	Yellow		White
	Orange		Green

**FURTHER INFORMATION**

Please contact Gill to discuss your specific requirements using the product reference 4128-00-060

## Custom designed military grade liquid level sensors

Robust, reliable liquid level sensor for defence applications

### DETAILED DIMENSIONS (SIDE VIEW)

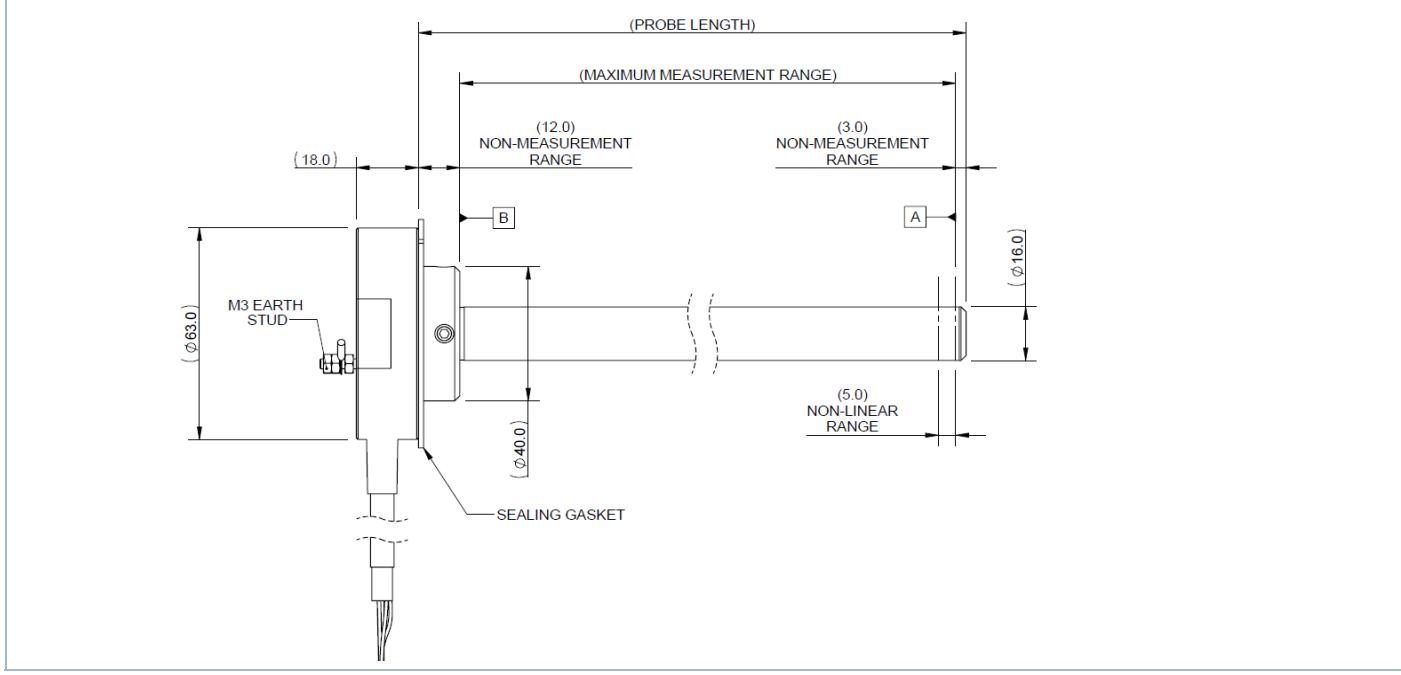

### DETAILED DIMENSIONS

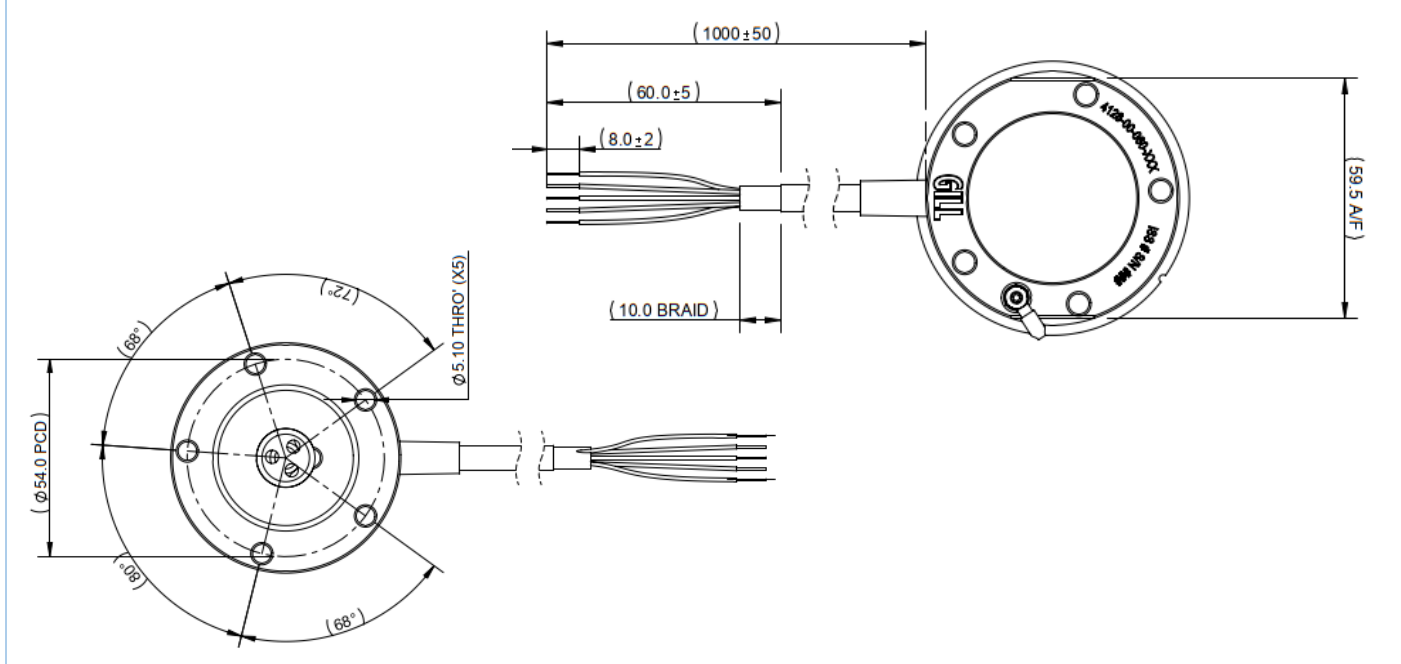

For more information about LevelDefend custom sensors, please contact Gill Sensors & Controls.

[gillsc.com](http://gillsc.com)

