

LevelPro

Industrial Liquid Level Sensor

Robust level sensors for varied applications

Manual



LevelPro

Industrial Liquid Level Sensors

Contents

1. Product description	3
1.1 Product overview	4
1.2 BSP, UNF and 5 bolt SAE models	4
1.3 NPT models	4
2. Getting started	6
3. Configuration	7
3.1 Tank profiling	8
4. Installation	9
4.1 Parts supplied	10
4.2 Cable length & strain relief	10
4.3 1.125" UNF Thread installation	11
4.3.1 Using the O-ring	11
4.3.2 Using the gasket	12
4.4 1.25" BSP Thread installation	13
4.4.1 Using the O-ring	13
4.4.2 Using the gasket	14
4.5 SAE 5-Bolt installation	15
4.6 2" NPT Thread installation	16
5. Specifications	17
5.1 General	17
5.2 Mechanical	17
5.3 Electrical	17
5.4 Analogue outputs	17
5.5 Connections	18
5.6 Part number configuration	18
6. Maintenance	19
7. Appendix	20

LevelPro

Industrial Liquid Level Sensors

1. Product description

LevelPro Liquid Level Sensor is designed for use in harsh environments at extreme operating temperatures where the continuous real-time liquid level monitoring of a variety of fuels, oils, chemicals, saline, and water is required. The sensor has no moving parts, floats or mechanical linkages providing excellent long term reliability.

Liquid level detection is achieved through solid-state capacitive technology. An outer tube and inner rod act as the plates of a capacitor, with any liquid providing the dielectric between the two. As the liquid level rises and falls, the capacitance of the sensor changes linearly. The on-board electronics process this and provide an output as a voltage or current signal.

Calibration of the sensor is achieved by setting a maximum (full) and minimum (empty) level for the desired liquid. The liquid level between these points is determined by proportionally relating the output to the two set points, while taking account for the dielectric constant value of the liquid.

If requested, further accuracy can be gained by compensating for the effect of temperature changes on the output in a given liquid with offsets across the temperature range.

Your chosen calibration has passed through Gill Sensors & Controls Limited's quality control to ensure the sensor provides market leading measurement accuracy in your specified liquid.

The sensor is designed to operate in fluids where deposits or build-up of sediment are not expected, as this may block the bleed holes unless they are regularly maintained. For fluids where deposits or build-up of sediment are expected, please contact Gill Sensors & Controls Limited for a suitable sensor.

Safety Warning, This equipment is not ATEX certified and has not been designed for use in areas which fall within the scope of the ATEX directive. If an area of intended usage is within the scope of the ATEX directive, then contact Gill Sensors & Controls Ltd for further information.

LevelPro

Industrial Liquid Level Sensors

A breakdown of the sensor is provided below with key measurement considerations. Please contact Gill for any additional information required.

The sensor electronics are housed in the flange, outside the measurement tank. The outer tube is placed into the measurement tank, such that will be submerged in liquid. The sensor can be installed using either built in thread or a five bolt SAE mounting, both providing a tank seal.

1.1 BSP, UNF and 5 bolt SAE models

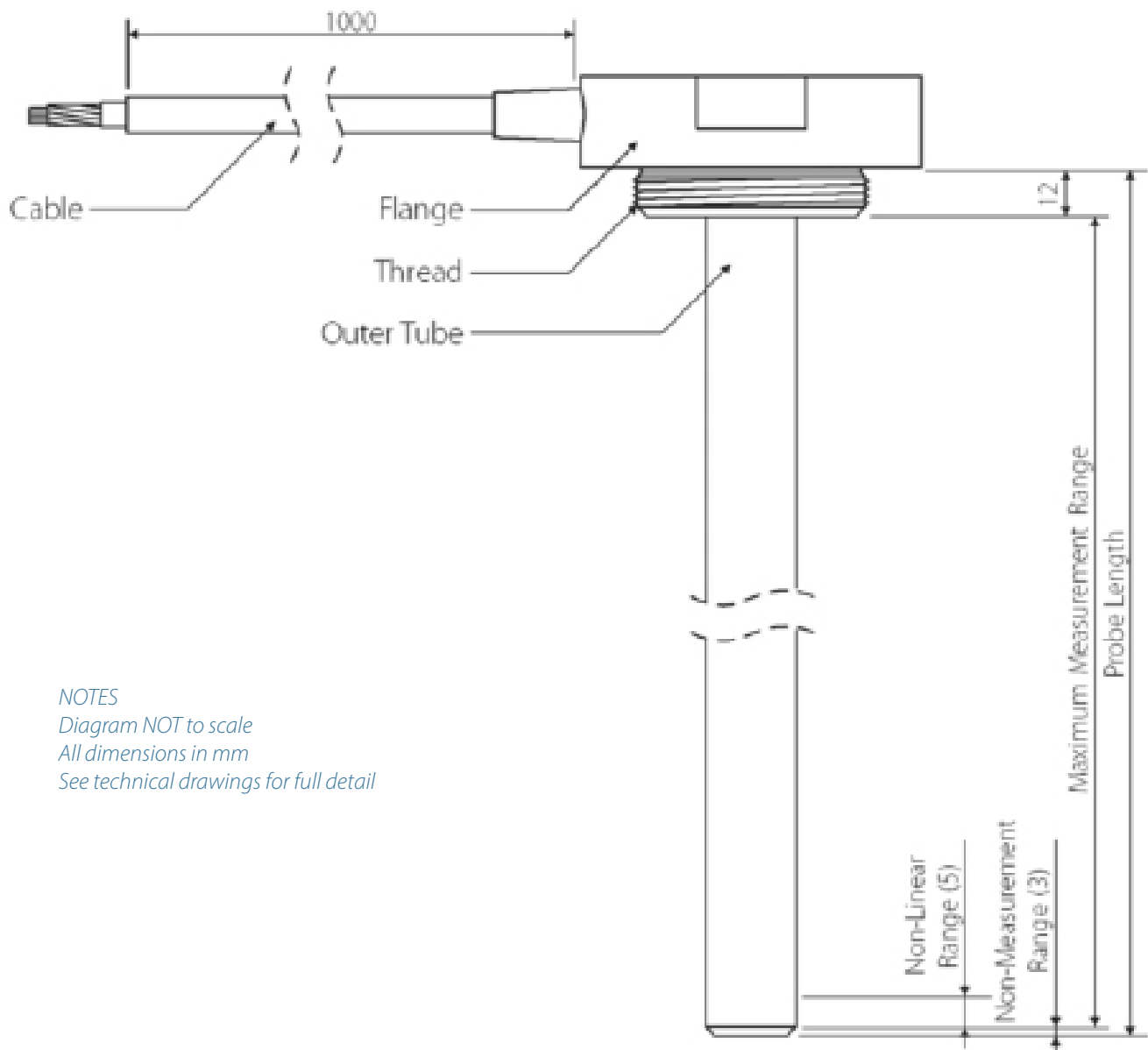

NOTES
Diagram NOT to scale
All dimensions in mm
See technical drawings for full detail

LevelPro

Industrial Liquid Level Sensors

1.3 NPT models

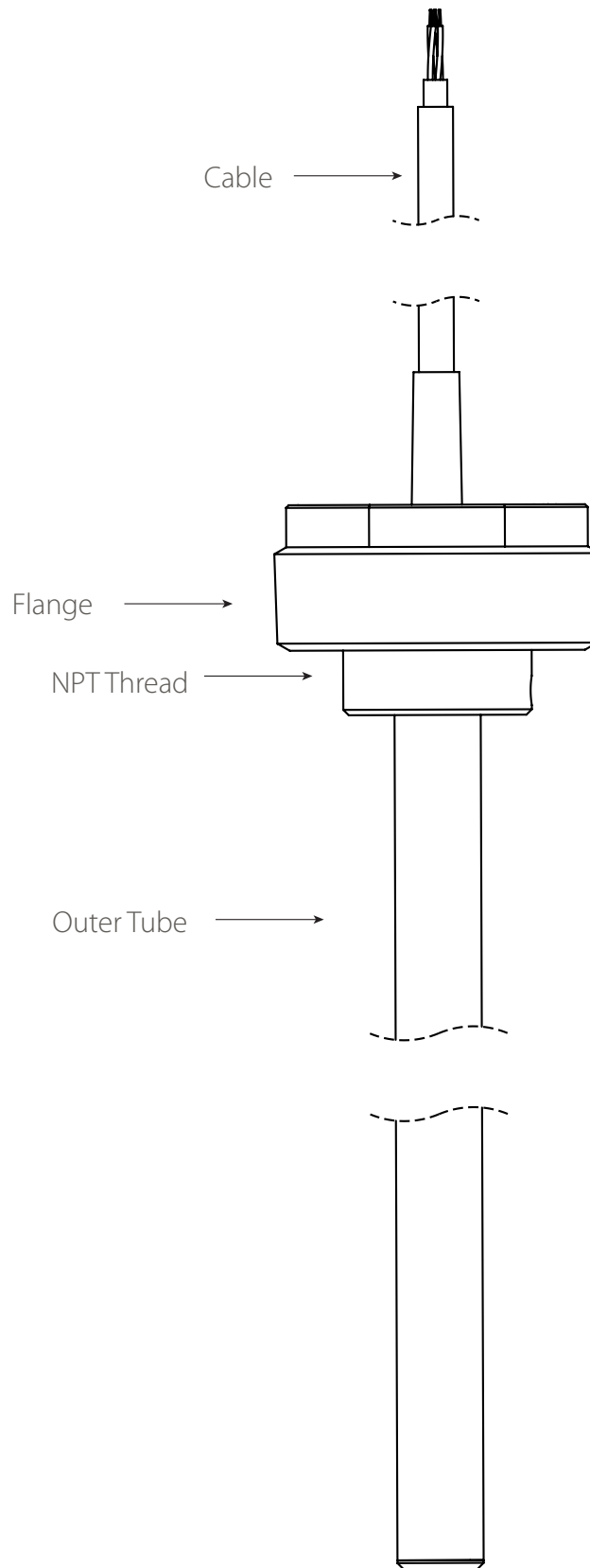



NOTES
Diagram NOT to scale
All dimensions in mm
See technical drawings for full detail

LevelPro

Industrial Liquid Level Sensors

2. Getting started

The analogue output cable has seven wires:

	Red	D.C. Power Supply
	Black	Ground
	Orange	Primary Output
	Yellow	Secondary Output
	White	TX
	Green	RX
	Silver	Drain Wire

The installation of the sensor has different requirements, depending on the analogue output:

Voltage

The sensor is provided with a factory calibrated output range of 0.25 V to 4.75 V. The sensor can be configured to a maximum output range of 0.25 V to 10 V.

The power supply must be at least 0.5V greater than the maximum output voltage required. The switch output requires a pull-up resistor of 1 kOhm to 10 kOhms.

Current

The current output is 4 – 20 mA. The measurement output requires a 250 Ohm load resistor across the output. The switch output requires a pull-up resistor of 1 kOhm to 10 kOhms.

	Voltage	Current
Supply Voltage	+5 to +32 VDC	+9 to +32 VDC
Over Voltage Protection	>32 VDC	>32 VDC
Supply Current @ 12 VDC	<15 mA	<15 mA
Reverse Polarity Protection	Yes	Yes
Analogue Resolution	10 bit	10 bit
Report Rate	10 Hz	10 Hz

LevelPro

Industrial Liquid Level Sensors

3. Configuration

The sensor can be configured using GSlevel software, available from www.gillsc.com/support. Select the 7010 Liquid Level Sensor from the "Select Product" dropdown list.

The minimum operating system requirements are:

- 32-bit (x86) or 64-bit (x64) processor
- Windows® 7 or later
- 1 Gb RAM
- 500 Mb disk space
- One free USB port to connect a sensor

A connector is required to configure the sensor with a computer. Gill Sensors & Controls Limited provide an RS232 to USB adaptor (P/N 1484-00-086). Please contact us if you require this device.

The GSlevel User Manual is accessible through the software. Install and run the software, then click the 'Help' button in the bottom right of the window, shown in the screenshot below.

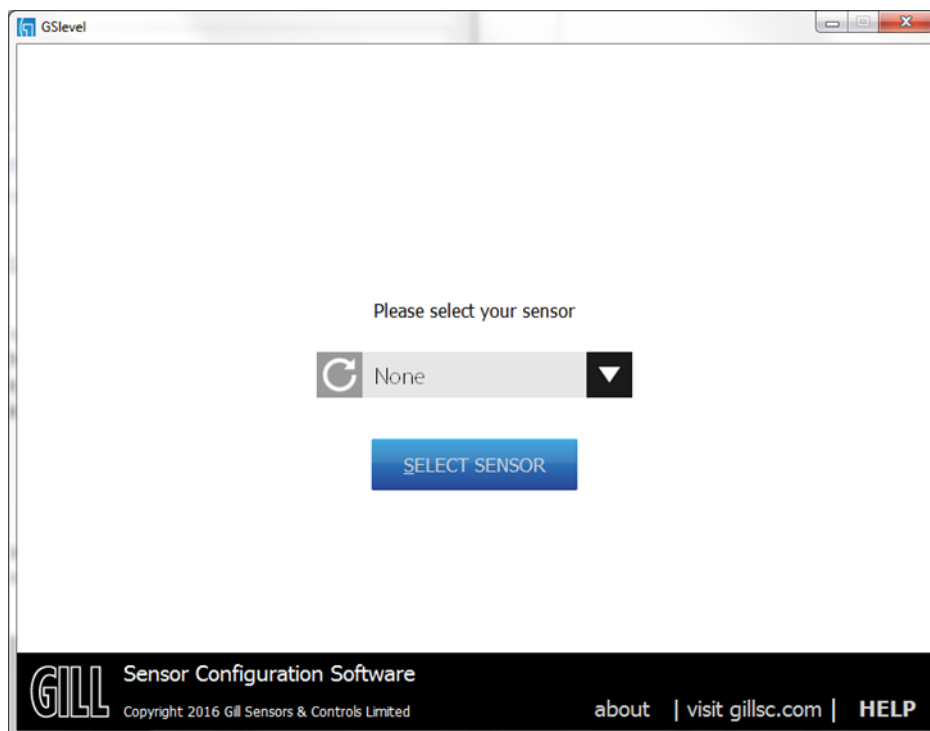

Click for GS level user manual

LevelPro

Industrial Liquid Level Sensors

3.1 Tank profiling

The sensor is configured for use with regular tank profiles, such as that shown below.

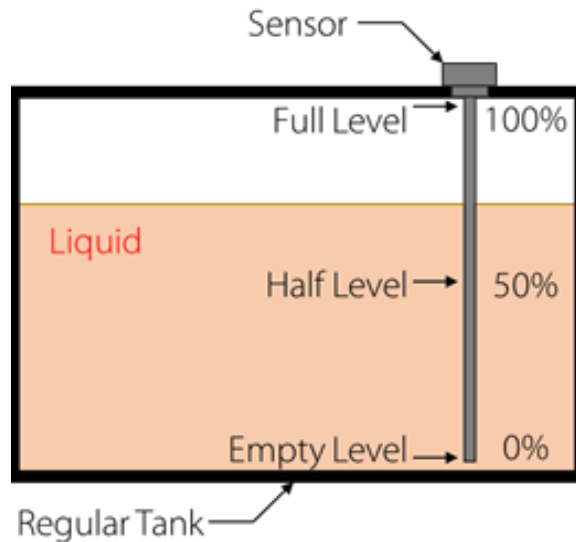

The sensor is supplied so that it reports the level in a linear path as the level rises. However, this will not be suitable for an irregular shaped tank, such as that shown below.

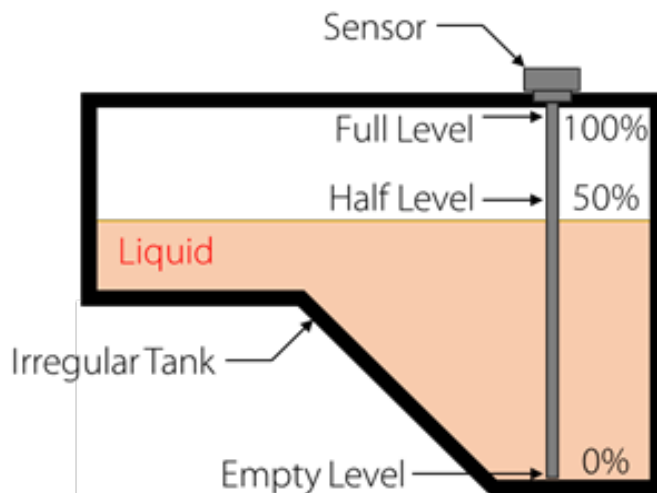

In this situation, 50% of the tank volume is not half way up the probe. To correct for this tank profiling can be used. This can be done in the GSlevel software and is covered in detail in the GSlevel User Manual.

LevelPro

Industrial Liquid Level Sensors

4. Installation

Do not remove the packaging until you are ready to install the sensor. Prior to installation, please check the sensor for any signs of transit damage. Contact Gill Sensors & Controls Limited immediately if this is the case.

IMPORTANT DO NOT attempt to cut the sensor to length or bend the sensor. Both actions will result in the sensor failing and will invalidate the warranty.

IMPORTANT The sensor must not be used in a tank that is not adequately vented.

IMPORTANT The sensor flange and cable must not be immersed in the liquid.

IMPORTANT Diagrams in this section are not to scale and are for reference only.

This manual covers installation of sensors in the conventional manner (see below). For inverted installation (see below) please contact Gill Sensors & Controls Limited.

Safety Warning, This equipment is not ATEX certified and has not been designed for use in areas which fall within the scope of the ATEX directive. If an area of intended usage is within the scope of the ATEX directive, then contact Gill Sensors & Controls Ltd for further information.

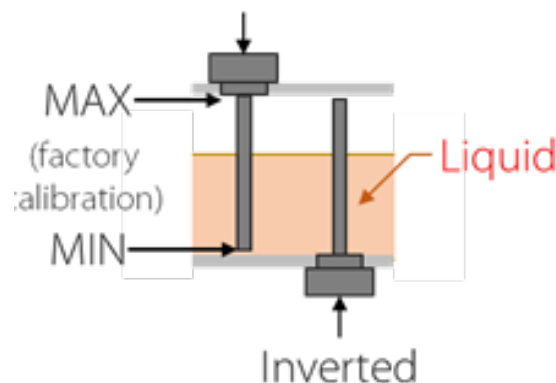

All 7010 sensors using the 1.125" UNF or 1.25" BSP fitting can be mounted using the SAE 5-bolt pattern using the supplied gasket. These sensor types can also be fitted with the supplied O-ring. The 2" NPT version has a tapered thread and is sealed as the thread is tightened onto the tank using either PTFE tape or pipe sealant (not included). Use of an O-ring or gasket is not necessary with this version of the sensor.

The sensor must be installed on a flat surface, such that it occupies the deepest part of the tank to be measured.

The sensor can be installed at any angle from vertical to a maximum recommended angle of 45°. For sensors over 500 mm in length in dynamic applications, in-tank support of the probe is recommended. Ensure that

LevelPro

Industrial Liquid Level Sensors

the mounting hole in the tank is strong enough to withstand the forces imposed by the sensor from its weight and the vibrations it may be exposed to. Please contact Gill Sensor & Controls Limited to discuss specific sensor requirements when mounted at an angle.

Before installation, ensure you have sufficient clearance above the tank in to order to mount the sensor. The sensor is rigid, therefore the clearance height must be, at a minimum, the designated length of the sensor plus 30mm to allow for the flange on sensors with 1.125" UNF or 1.25" BSP fittings. The 2" NPT sensor has a top exit cable and requires a minimum of 75mm clearance above the top of the tank. Sideways clearance may also be required, and should be accounted for.

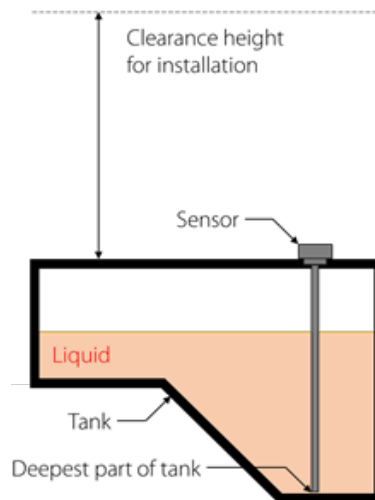

4.1 Parts supplied

7010 Liquid Level Sensor
O-ring and Gasket
Quick Start Guide

4.2 Cable length & strain relief

The sensor is provided with a flying lead of 1000mm, which may be shortened appropriate to the application. Ensure that the cable is secured to avoid damage during operation. It is recommended that cable length is kept to a minimum to prevent large voltage drops over the length of the cable which may affect the operation of the sensor.

Cable strain relief is provided at the sensor. Care should be taken not to stress the cable at the cable entry. The minimum recommended cable bend radius is 20mm. It is recommended that you do not connect the cable before installation.

LevelPro

Industrial Liquid Level Sensors

4.3 1.125" UNF Thread installation

The sensor is supplied with both an O-ring and a Gasket. To use the supplied O-ring, the mounting hole requires a chamfer to be machined around the upper edge. If a chamfer cannot be created, then the supplied Gasket should be used. Ensure that sufficient space is allowed around the sensor flange for the cable to bend.

4.3.1 Using the O-ring

The recommended mounting hole and chamfer size for the O-ring is shown below.

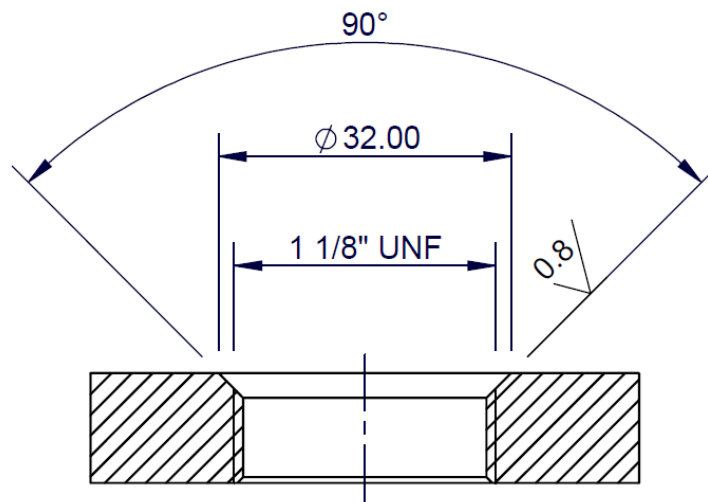

Fit the O-ring above the male thread on the sensor. Ensure the O-ring is centred and sits within the chamfer; tighten the sensor using an adjustable spanner until the sensor face is flush with the top of the tank and a torque of 50 Nm is achieved.

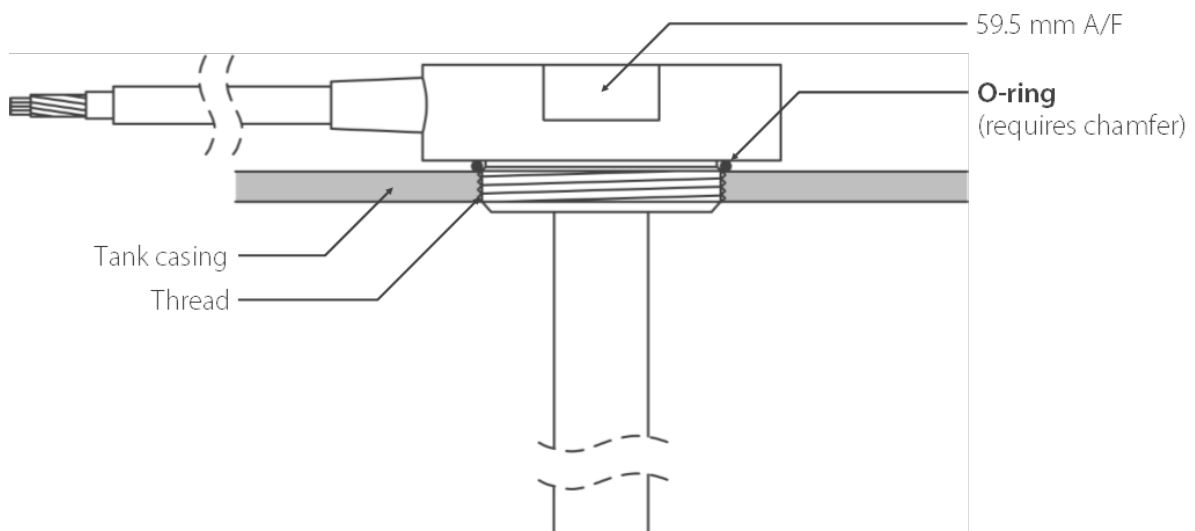

LevelPro

Industrial Liquid Level Sensors

4.3.2 Using the gasket

The recommended mounting hole for the gasket is shown below.

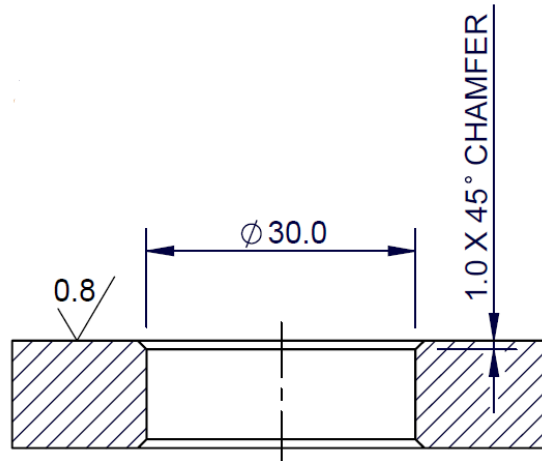

Fit the gasket over the thread mount, black face up. Ensure the gasket is centred under the sensor and tighten the sensor using an adjustable spanner to a torque of 50 Nm.

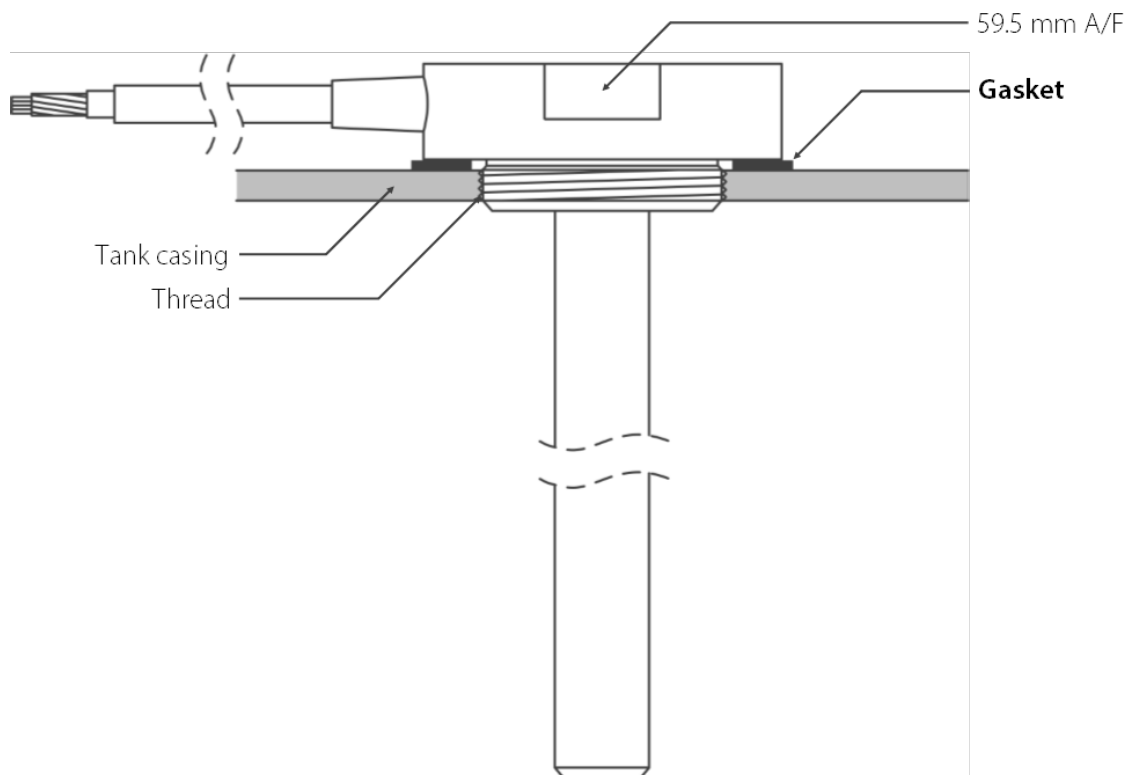

LevelPro

Industrial Liquid Level Sensors

4.4 1.25" BSP Thread installation

The sensor is supplied with both an O-ring and a Gasket. To use the supplied O-ring, the mounting hole requires a chamfer to be machined around the upper edge. If a chamfer cannot be created, then the supplied Gasket should be used. Ensure that sufficient space is allowed around the sensor flange for the cable to bend.

4.4.1 Using the O-ring

The recommended mounting hole and chamfer size for the O-ring is shown below.

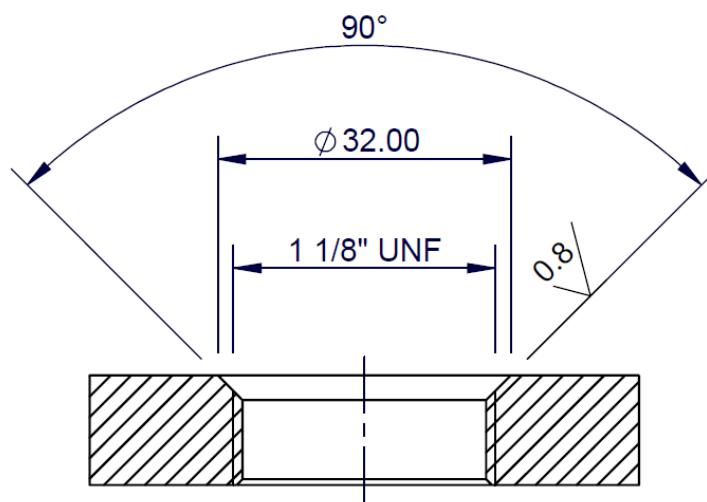

Fit the O-ring above the male thread on the sensor. Ensure the O-ring is centred and sits within the chamfer; tighten the sensor using an adjustable spanner until the sensor face is flush with the top of the tank and a torque of 50 Nm is achieved.

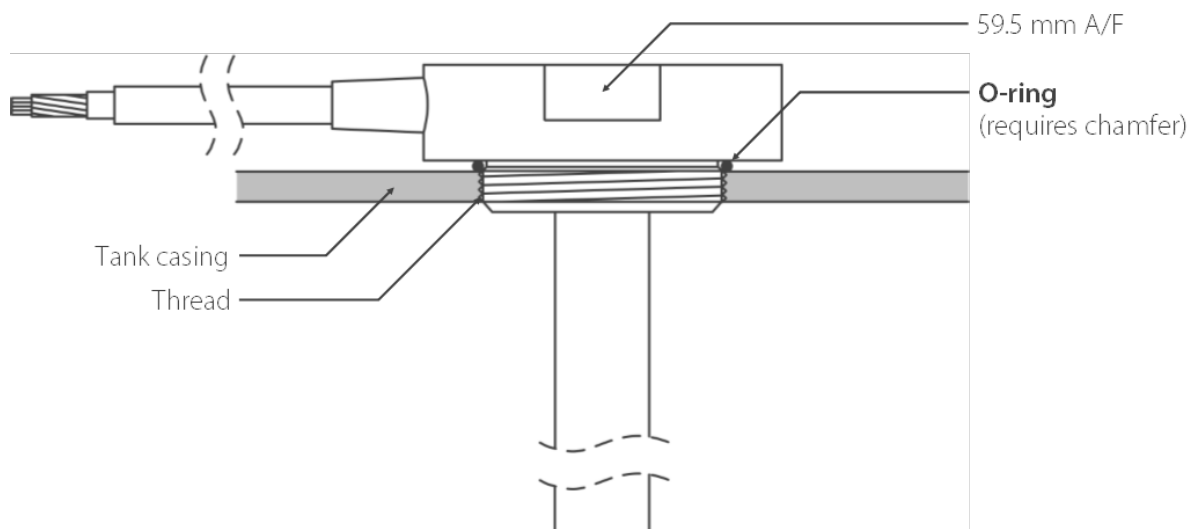

LevelPro

Industrial Liquid Level Sensors

4.4.2 Using the gasket

The recommended mounting hole for the gasket is shown below.

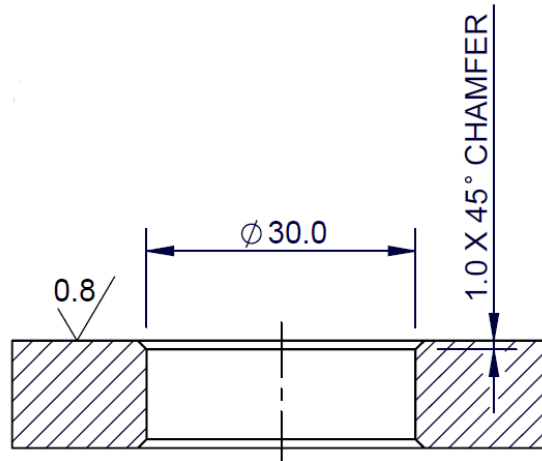

Fit the gasket over the thread mount, black face up. Ensure the gasket is centred under the sensor and tighten the sensor using an adjustable spanner to a torque of 50 Nm.

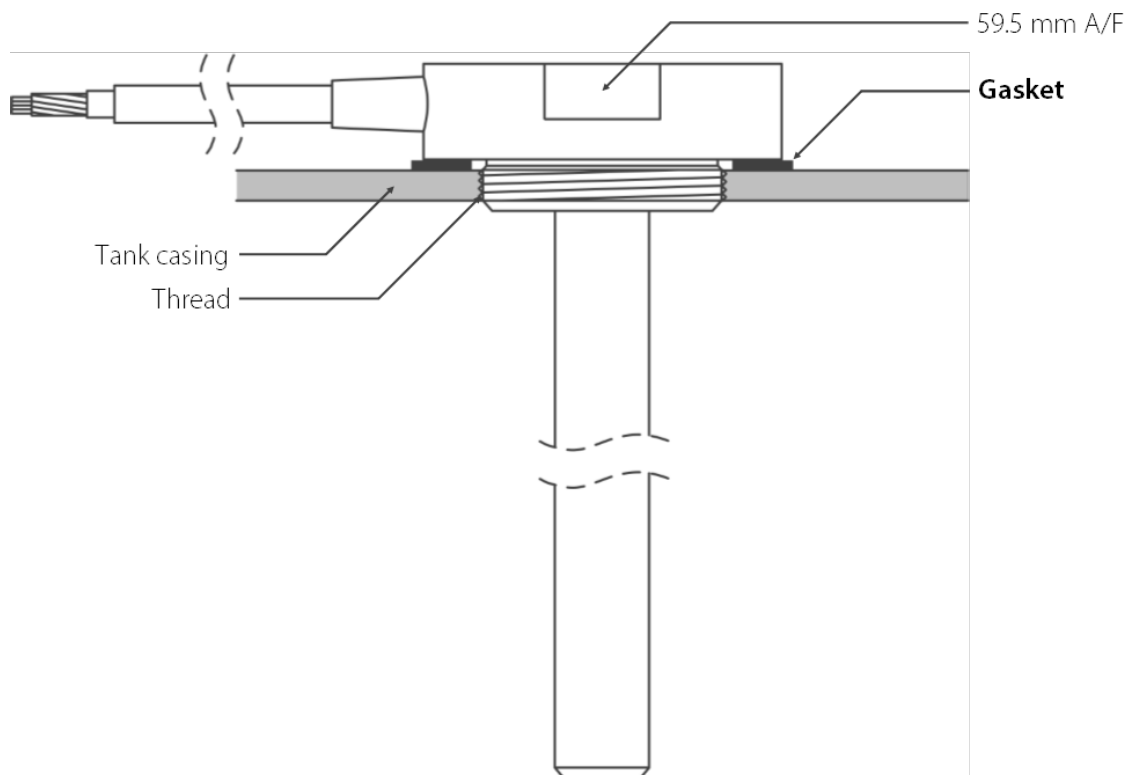

LevelPro

Industrial Liquid Level Sensors

4.5 SAE 5-Bolt installation

All 7010 sensors using the 1.125" UNF or 1.25" BSP fitting come with a SAE 5-bolt installation option. This installation option requires 5 holes to be tapped into the tank. The pattern for these holes is outlined below.

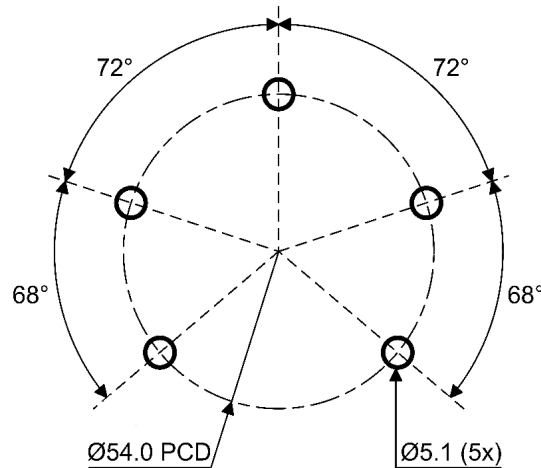

The sensor should be fitted with a gasket if the SAE 5-bolt installation method is used. Fit the gasket over the bolts, black face up, and tighten the bolts to a torque of 10 Nm each.

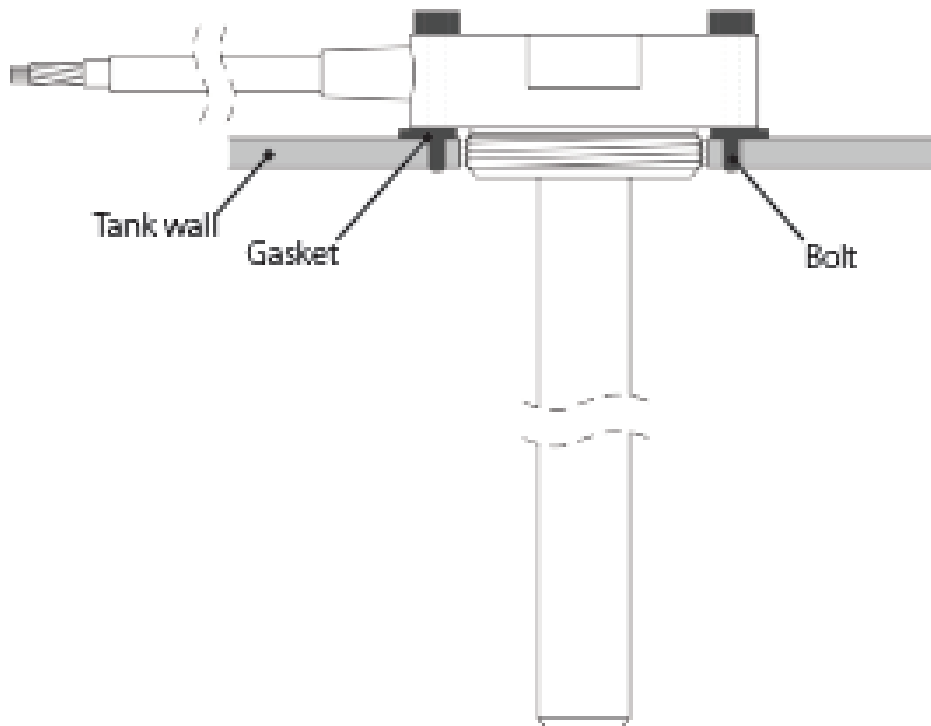

LevelPro

Industrial Liquid Level Sensors

4.6 2" NPT Thread installation

The 2" NPT version of the sensor uses a tapered thread system where a seal is made to the tank as the thread is tightened. The following diagrams give dimensions relevant to the installation. A suitable aperture should be made available in the tank to accept the 2" NPT fitting.

Use of PTFE tape or pipe sealant is recommended for this installation type.

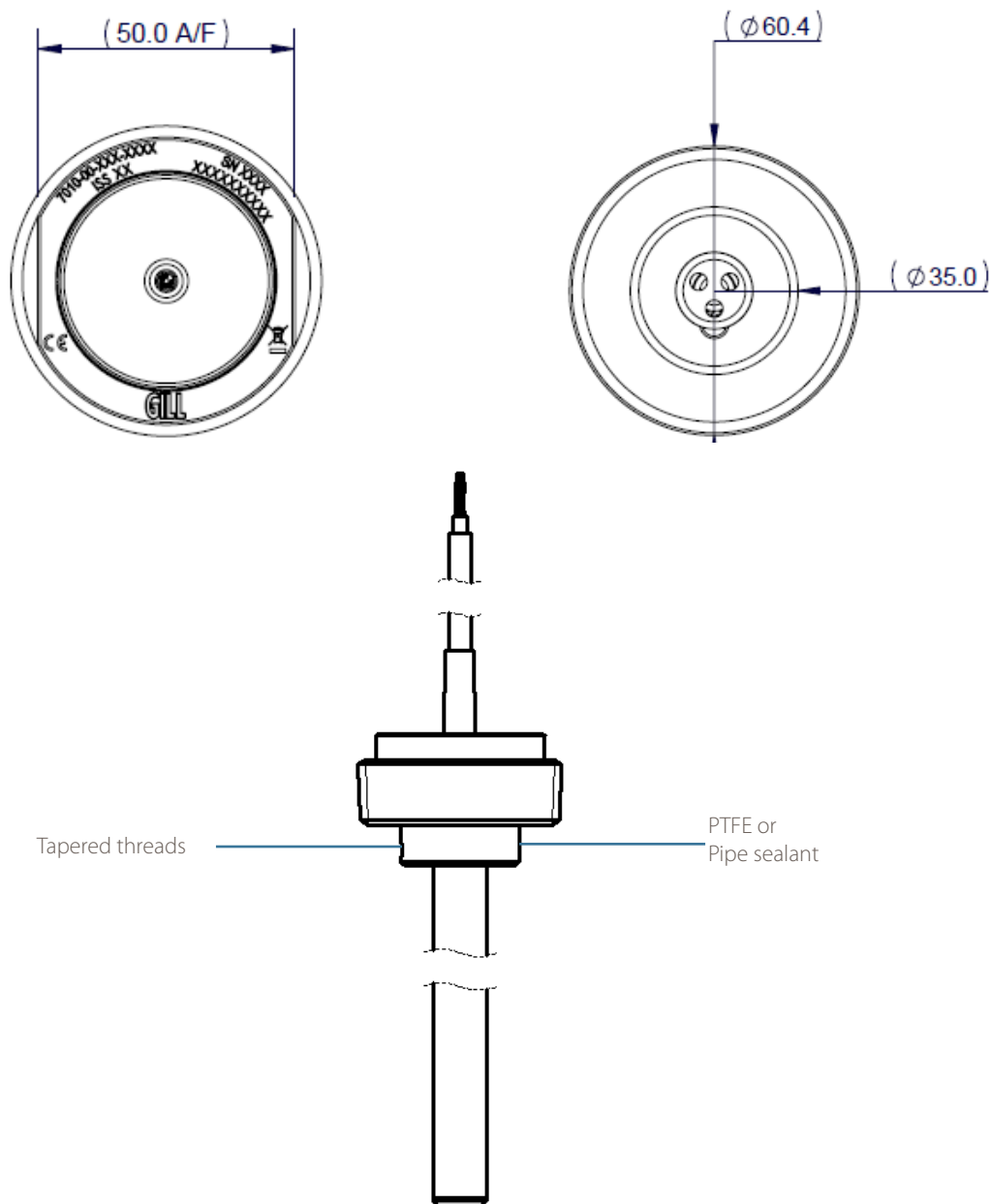

LevelPro

Industrial Liquid Level Sensors

5. Specifications

5.1 General

Primary Output Accuracy:	±2% FSD @ 20°C
Operating Temperature *:	-40 to 125°C * <i>Refer to product datasheet for temperature derating</i>
Humidity:	93% RH at 40°C
Pressure:	10 Bar (differential and absolute)
Compatible Media:	Fresh Water, Saltwater, Ethylene Glycol, Gasoline, Unleaded, LRP, Diesel Please consult Gill for other liquids
Seal Materials:	Fluorosilicone O-rings Klingersil Gasket
Ingress Protection:	IP66, IP68
EMC:	EN 61000, EN 61326, EN 60945

5.2 Mechanical

Construction Materials:	Stainless Steel 316, FEP, PEI
Probe Length:	100mm to 2000mm (in standard increments)
Mounting Options:	SAE 5-bolt; 1.125" UNF, 1.25" BSP or 2" NPT threaded
Weight:	From 300g (dependent on length)

5.3 Electrical

Voltage:	4-20 mA
Supply Voltage:	+5 to +32 VDC +9 to +32 VDC
Over Voltage Protection:	>32 VDC
Supply Current @ 12 VDC:	< 15 mA
Reverse Polarity Protection:	to -32 VDC
Analogue Resolution:	10 bit
Report Rate:	10 Hz
Sensor Configuration:	Accessible via USB

5.4 Analogue outputs

Factory Calibrated Output:	0.25 V – 4.75 V
Maximum Output Range:	0.25 V – 10.0 V
Current Output:	4 – 20 mA
Switch Output:	Open collector output 50 V / 1A max Switch to ground

LevelPro

Industrial Liquid Level Sensors

5.5 Connections

Cable: 20 AWG TYPE 44, DR25 sleeving
Cable Tail Length: 1000mm

5.6 Part number configuration

The configuration of the sensor can be determined from its part number designation, engraved on the flange. The interpretation of the part number designation is outlined below.

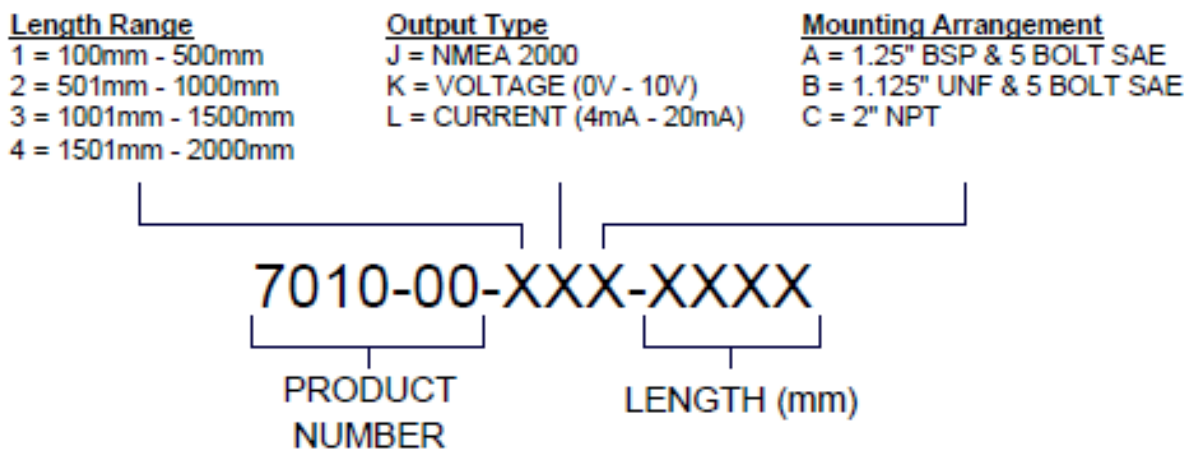

LevelPro

Industrial Liquid Level Sensors

6. Maintenance

The sensor requires no maintenance to function correctly. There are no user serviceable or moving parts within the sensor.

For correct operation it is important to configure the sensor by installing and running the GSlevel sensor user software from the Gill website (www.gillsc.com/software). This software will allow setup of the correct output and, through using the tank profiling feature, will offset the effect of irregular shaped tanks on the accuracy of the measured level.

Please contact Gill Sensors or Controls Ltd using the details at the end of this document in the first instance with any further issues to be resolved.

Where necessary a product return may only be arranged with prior authorisation from Gill Sensors & Controls Ltd. An RMA authorisation number will be issued to allow tracking through company systems and efficient resolution. Please DO NOT return the sensor without having first obtained an RMA number.

When the product has reached end of life, please dispose of responsibly according to local waste disposal regulations.

LevelPro

Industrial Liquid Level Sensors

7. Appendix



EU DECLARATION OF CONFORMITY

In accordance with Ref. Ares(2015)1600946 - 15/04/2015

This declaration of conformity is issued under the sole responsibility of the manufacturer:

Manufacturer	Gill Sensors & Controls Limited, Unit 600 Ampress Park, Lymington, SO41 8LW. United Kingdom	
Authorised Representative	ProductIP AR Services Rubensstraat 211, 6717 VE EDE The Netherlands (for authorities only)	
Object of the Declaration Description	LEVEL SENSOR LIQUID LEVELPRO	
Object of the Declaration Part Numbers	7010-00-1KA-xxxx, 7010-00-1KB-xxxx, 7010-00-1KC-xxxx, 7010-00-1LA-xxxx, 7010-00-1LB-xxxx, 7010-00-1LC-xxxx, 7010-00-2KA-xxxx, 7010-00-2KB-xxxx, 7010-00-2KC-xxxx, 7010-00-2LA-xxxx, 7010-00-2LB-xxxx, 7010-00-2LC-xxxx, 7010-00-3KA-xxxx, 7010-00-3KB-xxxx, 7010-00-3KC-xxxx, 7010-00-3LA-xxxx, 7010-00-3LB-xxxx, 7010-00-3LC-xxxx, 7010-00-4KA-xxxx, 7010-00-4KB-xxxx, 7010-00-4KC-xxxx, 7010-00-4LA-xxxx, 7010-00-4LB-xxxx, 7010-00-4LC-xxxx	

The object of the declaration described above is in conformity with the relevant Union harmonisation legislation:

Reference	Description
2014/30/EU	Electromagnetic Compatibility (EMC) Directive
2011/65/EU + (EU)2015/863	Restriction of Hazardous Substances (RoHS) Directive + amendments

References to the relevant harmonised standards used, or references to the specifications in relation to which conformity is declared:

Reference	Description
EN 60945:2002	Maritime navigation and radio communication equipment and systems. General requirements. Methods of testing and required test results
EN 61326-1:2013	Electrical equipment for measurement, control and laboratory use. EMC requirements. Particular requirements.

Signed for and on behalf of: Gill Sensors & Controls Limited

Place of Issue	Lymington, United Kingdom
Date of Issue	15th July 2021
Name	Elizabeth Phillips
Function	Director
Signature	



Document Reference Number: 9180-0014

LevelPro

Industrial Liquid Level Sensors

Important Notices:

- Gill Sensors & Controls Limited can take no responsibility for installation and/or use of its equipment if this is not done in accordance with the appropriate issue and/or amendment of the manual.
- The user of this manual should ensure that it is appropriate in all details to the exact equipment to be installed and/or operated. If in doubt, the user should contact Gill Sensors & Controls Limited for advice.
- If further details are required which do not appear in this manual, contact Gill Sensors & Controls Limited or one of our
- Install and use LevelPro Liquid Level Sensor in accordance with local laws and regulations.
- Gill Sensors & Controls Limited are continually enhancing their products and specifications and reserve the right to change or revise the information supplied in this document without notice and without obligation to notify any person or organisation of such revision or change.
- The information contained in this manual remains the property of Gill Sensors & Controls Limited and should not be copied or reproduced for commercial gain.

Help Us to Help You:

Every effort has been made to ensure the accuracy in the contents of our documents, however, Gill Sensors & Controls Limited can assume no responsibility for any errors or omissions in our documents or their consequences. Gill Sensors & Controls Limited would greatly appreciate being informed of any errors or omissions that may be found in the contents of any of our documents.

Gill Sensors & Controls Limited
Unit 600, Ampress Park, Lymington,
Hampshire, SO41 8LW, UK
Tel: +44 1590 613900, Fax: +44 1590 613901
Email: info@gillsc.com, Website: www.gillsc.com